



SMARTTRUCK™

PICKUP
TRUCK



SAFETY, FLEXIBILITY & ACCURACY

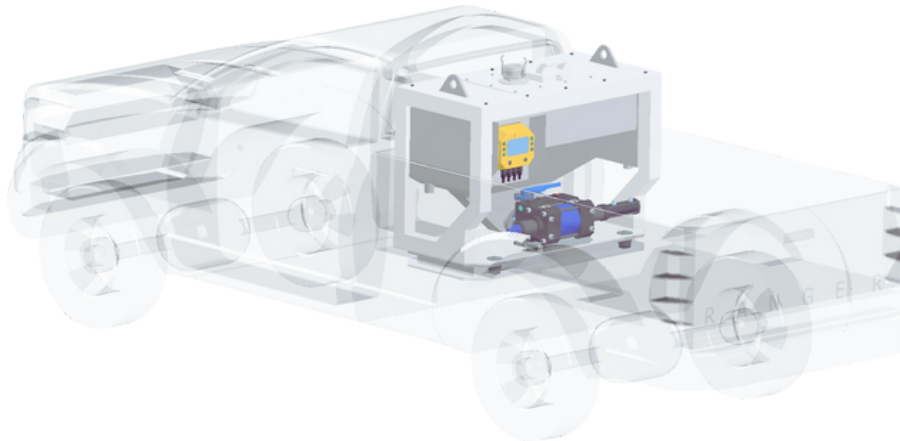

PRODUCT DESCRIPTION

The SMARTTRUCK™ Pickup loading system has been designed for flexibility throughout underground, surface & civil loading operations. The compact design allows the Pickup delivery system to access remote, inaccessible & confined loading patterns with speed and flexibility, saving on traveling & standing time for larger loading systems in the fleet.

The flexibility offered through the SMARTTRUCK™ Pickup delivery system makes it ideal to use in secondary blasting, wall control and civil loading operations. Pickup pumping systems are built to fit preferred customer chassis and are designed to carry payloads from 400kg to 1'500kg and achieve loading rates up to 120 kg/min.

Integrated with the iMining BLASTTRACK™ smart control & SMARTGPS™ technology, supervisors have on-demand access to live loading reports and energy placement in the pattern. While operators have the tools for precise shot placement in precision blasting operations & live condition monitoring for prompts for operator action for optimal blast outcomes.

The SMARTTRUCK™ Pickup delivery system has been made possible through the development of SMARTFLOW™ positive displacement pump technologies that promote efficiency, safety & consistency in bulk loading operations. Single and dual delivery pump systems are available.

See SMARTFLOW™ pump systems spec. sheet for pump data.

BENEFITS

- Flexibility for inaccessible blasting patterns
- Civil, surface & secondary blasting operations
- Free the loading availability of expensive pump trucks and operators during secondary blasting operations
- Improve safety through SMARTFLOW™ low friction positive displacement pump technology
- Improve productivity in manual loading operations
- Reduce operating costs

DESIGN FEATURES

- Gassed or MB sensitized pumpable formulations
- Customizable carrying capacity from 400kg to 1'500kg
- Flow rate up to 120kg/min
- Precise mass placement
- Single or dual delivery lines available
- BLASTTRACK™ control system improving safety & performance with real-time reporting
- Visibility over performance & utilization