



PICKUP

PUMPING
UNIT



PICKUP MOUNTED PUMPING SYSTEMS FITTED WITH STATE-OF-THE-ART PUMP AND CONTROL SYSTEMS FOR COMPLETE TRANSPARENCY

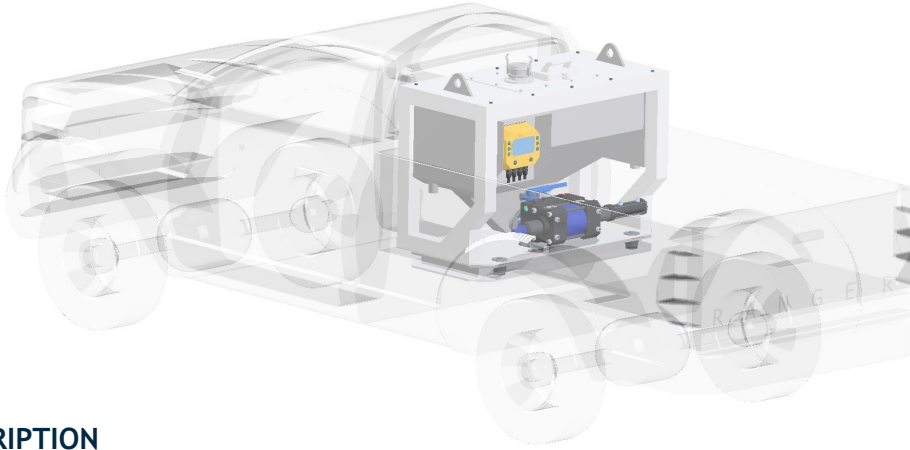

PRODUCT DESCRIPTION

The PICKUP pumping system has been designed for robustness and easy manoeuvring on any underground or surface mine. The smaller design allows the vehicle to reach areas which could be difficult or time consuming to get to when using a larger vehicle such as an MMU. This makes the vehicle ideal to use for secondary blasting applications, wall control blasting or during cap blasting operations.

The PICKUP truck is designed to carry a load of either 800kg, or 400kg. Both of these tank designs fit on either a single cap pick-up truck, or onto an underground vehicle. By using the BLASTTRACK™ controller, the operator can set the charging mass to an accuracy of 100g to ensure the necessary blast results are achieved.

For optimal safety, product consistency and machine availability in loading operations, the SMARTFLOW™ positive displacement pump technologies are recommended throughout emulsion loading operations. SMARTFLOW™ pumps are designed as standalone explosive manufacturing units eliminating frictional heat build-up through the use of diaphragms to deliver both emulsion and sensitizer in pre-set ratios. Single pump and double pump charging units are available with integrated condition monitoring to facilitate preventative maintenance.

BENEFITS

- Easy manoeuvring over any mining surfaces
- Can be used for surface or underground mining operations
- Does not interrupt the charging time line when secondary blasting has to take place.
- Higher production rates
- Significantly improved safety through SMARTFLOW™ positive displacement diaphragm pump technology
- Low capital outlay due to compliancy with any single cab truck.
- Reduced complexity and down-time of charging unit

DESIGN FEATURES

- Designed in an 800kg or 400kg carrying capacity.
- Compatible with a ½” - 2” charging hose
- Fitted with iMining’s BLASTTRACK™ control system improving safety and operational transparency through operator ID, loading trends, flow rates, pressures and real-time failure analysis.
- Transparency over charging fleet location & utilisation, product quality control, product consumption and individual operator performance